



G20 Auditorium Seating Assembly Instructions

INTRODUCTION

The G20 auditorium seating system is intended to be used in a commercial setting. The system consists of the following components:

- Right Arm Standard
- Right Tablet Arm Standard
- Left Arm Standard
- Left Tablet Arm Standard
- Center Arm Standard
- Center Tablet Arm Standard
- ADA Arm Standard
- Gravity Uplift Seat
- Standard Seat Back
- High Seat Back
- Power System

Note: Read these assembly instructions carefully prior to product installation. Electrically interconnected furnishings must also be mechanically interconnected. Product failure and personal injury may result if instructions are not followed.

TOOLS REQUIRED

- Hammer drill and 1/4" masonry bit for concrete anchor holes
- Drill and bit for pilot holes in wood floor
- #3 Phillips head screw driver
- #2 Phillips head screw driver
- Wrench Set
- Socket Set
- Allen Wrench (Metric)
- 4' Level
- 6-8' Flexible straight edge 1/4 round or equivalent
- 25 and 100' Tape Measure
- Tailor's Chalk
- G20 Drill Template

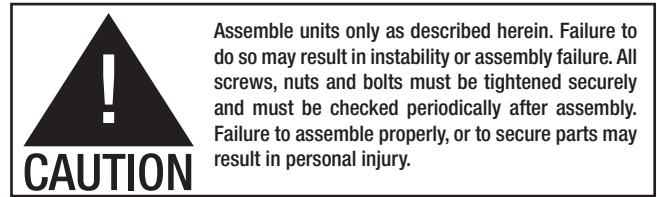

IMPORTANT SAFETY INSTRUCTIONS

When using an electrical furnishing, basic precautions should always be followed, including the following:

Read all instructions before installing the G20 Chair

WARNING:

1. Risk of Electrical Shock - Connect this furnishing to a properly grounded outlet only. See Grounding Instructions.
2. Do not use outdoors.
3. Use this furnishing only for its intended use described in these instructions. Do not use attachments not recommended by the manufacturer.
4. The maximum intended load for this seat is 300 pounds (102 Kilograms).
5. Functional Tablet Load - 20 Pounds (9 kg)

GROUNDING INSTRUCTIONS

This product must be connected to a grounded metal, permanent wiring system, or an equipment-grounding conductor must be run with the circuit conductors and connected to the equipment-grounding terminal or lead on the product.

Note: The power infeeds are to be connected to the power source by a qualified electrician who must also check the electrical integrity of the finished system installation.

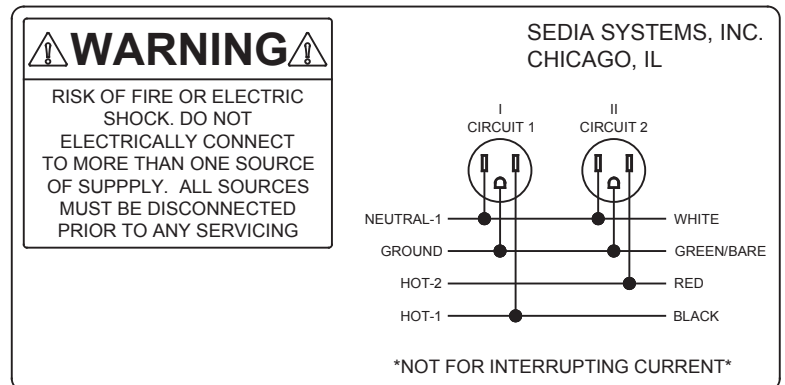

SAVE THESE INSTRUCTIONS

G20 Auditorium Seating Assembly Instructions

MINIMUM CONSTRUCTION REQUIREMENTS

Wood Floors

- Minimum two layers of 3/4" thick plywood
- APA rated grade plywood
- Allow minimum embedment 1-1/2" with lag screws
- Use toggle bolt if less than 1-1/2" embedment

Concrete Floors

- 3000 psi concrete compressive strength
- 3" thick free of obstruction for 1-1/2"
- Minimum anchor embedment 1-1/2"

Note: Warranty null and void if Sedia Systems R40 Seating product line is installed on flooring that does not meet the minimum structural requirements stated above.

FLOOR FASTENER REQUIREMENTS

Wood Floors

- 3/8" x 2-1/2" lag bolts
- 3/8" flat washers
- (2) Bolt assemblies required per arm standard

Concrete Floors

- 1/4" x 2-5/8" concrete anchors
- 3/8" flat washers
- (2) Bolt assemblies required per arm standard

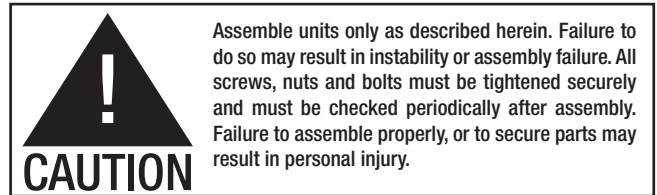

Site Preparation

1. Read and review the Assembly Instructions.
2. Review project drawings and layouts.
3. Locate floor center.
4. Locate row size line.
5. Draw size line for straight or radius rows.
6. Mark hole centerline for first chair.
7. Mark incremental hole centerline locations.
8. Use drill template to mark hole locations.
9. Use carpet punch at each hole location.
10. Locate and drill anchor holes into floor.
11. Vacuum holes to remove debris.

Chair Installation

12. Mount arm channel to the floor with anchor bolts.
13. Assemble arms to arm channel with screws.
14. Align seat back bracket to holes on arm standard.
15. Assemble seat by aligning pins with pivot disc slot.
16. Install arm channel cover.

Steps for Installing Power Option

Before assembling seat:

1. Attach bracket and H Block to center of seat back.
2. Connect the duplex module and jumper cable to the H Block. Continue connecting jumper cables and duplex modules per the layout drawings.
3. Install the raceway end caps to each side.
4. Install the raceway cover so it overlaps the end caps.
5. Assemble seat by aligning pins with pivot disc slot.
6. Install arm channel cover.
7. Connect electrical whip to the main power source.
8. Mount row and seat numbering (optional).
9. Clean product and site for walk through.

Note: Dimensional spacing referenced is centerline to center line unless otherwise noted.

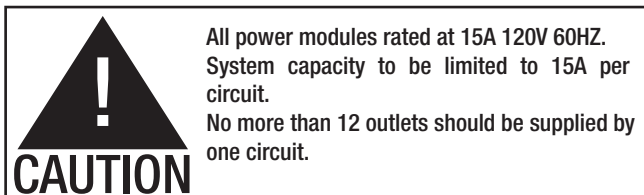

G20 Auditorium Seating Assembly Instructions

ROUTINE CARE AND MAINTENANCE

1. All parts are lubricated for life.
2. Any service should be conducted by an authorized service representative.
3. Perform periodic inspections for loose or broken parts.

LAMINATE: To clean the surface, use a damp cloth or sponge and a mild soap or detergent. Difficult stains such as coffee or tea can be removed using a mild household cleaner and baking soda; mixing to achieve a paste consistency. Use a stiff nylon bristle brush, scrubbing (approx. 15-20 strokes) the affected area. Do not scrub so as to mar (damage, scratch) the surface finish. Stubborn stains that resist any of the above cleaning methods may require the use of undiluted household bleach or nail polish remover. Use a cotton ball saturated with bleach or nail polish remover (acetone); gently rub the stain for up to two minutes. Rinse thoroughly with warm water and wipe dry using a soft cloth. This step may be repeated if the stain appears to be going away and the color of the laminate has not been affected.

CAUTION:

Prolonged exposure of the laminate and powder coat surfaces to bleach will cause discoloration. Always rinse laminate and powder coat surfaces after cleaning! Failure to rinse after cleaning can cause damage; even if a small amount of cleaning solution remains on the surface. A dry residue may be invisible; however, moisture from cups or drinks can reactivate it, and result in permanently etched scars or stains over time.

Recommended Household Cleaners:

- Clorox®* • Formula 409® • Dawn® • Fantastik®
- Dow Bathroom Cleaner with Scrubbing Bubbles™
- Favor® • Windex® • Lestoil® • Glass Plus®
- Pledge® • Grease Relief® • Mr. Clean® • TOP JOB®
- Lysol® Brand Disinfectant Basin/Tub/Tile Cleaner

* Prolonged exposure can mar the surface

CAUTION:

Acidic or **abrasive** cleaners can damage laminate and powder coat surfaces; do not use them. Drain cleaners containing lye will permanently damage the laminate surface. If you spill a drain cleaner, wipe it up immediately and rinse several times with water. Hair, textile and food **dyes** can cause permanent stains. If dye should happen to spill, wipe it up immediately with dishwashing detergent or an all-purpose cleaner. Wipe spills away promptly and rinse several times with water.

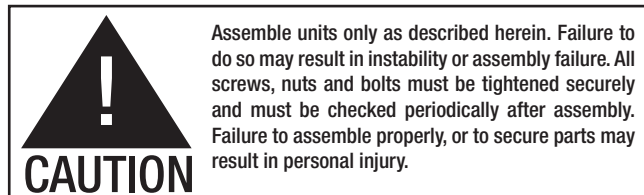

Rust removers contain harsh chemicals, which will quickly cause permanent damage. If a spill occurs, wipe off all residues immediately, wash thoroughly with soapy water and rinse several times. Steel wool and other abrasive pads will damage the laminate and powder coat face. Do not use them for cleaning and don't store steel wool pads on your countertop; the metal can rust and leave stains. Toilet bowl cleaners contain harsh chemicals that can cause permanent damage. If spills occur, wipe up immediately, wash surface with soapy water and rinse several times.

The cleaners listed below can cause damage to the surface of laminate:

Chemical Ingredient	Synonymous Names
Hydrochloric Acid	Muriatic Acid Hydrogen Chloride
Sulfuric Acid	Oleic Acid Oil of Vitriol Oleum
Hydrofluoric Acid	Rust Remover
Phosphoric Acid	Rust Remover
Sodium Hydroxide	Caustic Soda Caustic Soda Lye Lye
Pumice (abrasive)	

Remember, sharp objects can damage the surface of laminate and powder coat surfaces, marring its beauty and lowering wear and stain resistance. Although the laminate and powder coat surfaces are somewhat resistant to scratch and marring, they can be damaged, even under normal use.

Laminate and powder coat surfaces may need occasional dusting depending on where it's used. To keep the surface beautiful, use a non-oily furniture spray. (Remember to clean the spray off several times a year to prevent build-up.) Furniture polish can also help hide fine scratches in the surface.

UPHOLSTERED FABRIC: Clean with water-based cleaning agents, foam or pure water-free solvents. Vacuuming or light brushing is recommended to prevent dust and soil buildup. For answers to additional questions regarding care or cleaning please contact Sedia Systems.

G20 Auditorium Seating Assembly Instructions

MINIMUM CONSTRUCTION REQUIREMENTS

Wood Floors

- Minimum two layers of 3/4" thick plywood
- APA rated grade plywood
- Allow minimum embedment 1-1/2" with lag screws
- Use toggle bolt if less than 1-1/2" embedment

Concrete Floors

- 3000 psi concrete compressive strength
- 3" thick free of obstruction for 1-1/2"
- Minimum anchor embedment 1-1/2"

Note: Warranty null and void if Sedia Systems R40 Seating product line is installed on flooring that does not meet the minimum structural requirements stated above.

FLOOR FASTENER REQUIREMENTS

Wood Floors

- 3/8" x 2-1/2" lag bolts
- 3/8" flat washers
- (2) Bolt assemblies required per arm standard

Concrete Floors

- 1/4" x 2-5/8" concrete anchors
- 3/8" flat washers
- (2) Bolt assemblies required per arm standard

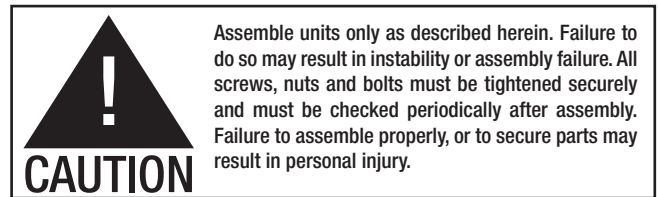

Site Preparation

1. Read and review the Assembly Instructions.
2. Review project drawings and layouts.
3. Locate floor center.
4. Locate row size line.
5. Draw size line for straight or radius rows.
6. Mark hole centerline for first chair.
7. Mark incremental hole centerline locations.
8. Use drill template to mark hole locations.
9. Use carpet punch at each hole location.
10. Locate and drill anchor holes into floor.
11. Vacuum holes to remove debris.

Chair Installation

12. Mount arm channel to the floor with anchor bolts.
13. Assemble arms to arm channel with screws.
14. Align seat back bracket to holes on arm standard.
15. Assemble seat by aligning pins with pivot disc slot.
16. Install arm channel cover.

Steps for Installing Power Option

Before assembling seat:

1. Attach bracket and H Block to center of seat back.
2. Connect the duplex module and jumper cable to the H Block. Continue connecting jumper cables and duplex modules per the layout drawings.
3. Install the raceway end caps to each side.
4. Install the raceway cover so it overlaps the end caps.
5. Assemble seat by aligning pins with pivot disc slot.
6. Install arm channel cover.
7. Connect electrical whip to the main power source.
8. Mount row and seat numbering (optional).
9. Clean product and site for walk through.

Note: Dimensional spacing referenced is centerline to center line unless otherwise noted.

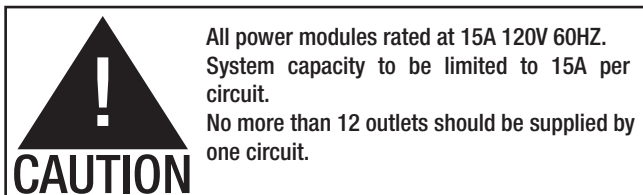

G20 Auditorium Seating Assembly Instructions

ROUTINE CARE AND MAINTENANCE

1. All parts are lubricated for life.
2. Any service should be conducted by an authorized service representative.
3. Perform periodic inspections for loose or broken parts.

LAMINATE: To clean the surface, use a damp cloth or sponge and a mild soap or detergent. Difficult stains such as coffee or tea can be removed using a mild household cleaner and baking soda; mixing to achieve a paste consistency. Use a stiff nylon bristle brush, scrubbing (approx. 15-20 strokes) the affected area. Do not scrub so as to mar (damage, scratch) the surface finish. Stubborn stains that resist any of the above cleaning methods may require the use of undiluted household bleach or nail polish remover. Use a cotton ball saturated with bleach or nail polish remover (acetone); gently rub the stain for up to two minutes. Rinse thoroughly with warm water and wipe dry using a soft cloth. This step may be repeated if the stain appears to be going away and the color of the laminate has not been affected.

CAUTION:

Prolonged exposure of the laminate and powder coat surfaces to bleach will cause discoloration. Always rinse laminate and powder coat surfaces after cleaning! Failure to rinse after cleaning can cause damage; even if a small amount of cleaning solution remains on the surface. A dry residue may be invisible; however, moisture from cups or drinks can reactivate it, and result in permanently etched scars or stains over time.

Recommended Household Cleaners:

- Clorox®* • Formula 409® • Dawn® • Fantastik®
- Dow Bathroom Cleaner with Scrubbing Bubbles™
- Favor® • Windex® • Lestoil® • Glass Plus®
- Pledge® • Grease Relief® • Mr. Clean® • TOP JOB®
- Lysol® Brand Disinfectant Basin/Tub/Tile Cleaner

* Prolonged exposure can mar the surface

CAUTION:

Acidic or **abrasive** cleaners can damage laminate and powder coat surfaces; do not use them. Drain cleaners containing lye will permanently damage the laminate surface. If you spill a drain cleaner, wipe it up immediately and rinse several times with water. Hair, textile and food **dyes** can cause permanent stains. If dye should happen to spill, wipe it up immediately with dishwashing detergent or an all-purpose cleaner. Wipe spills away promptly and rinse several times with water.

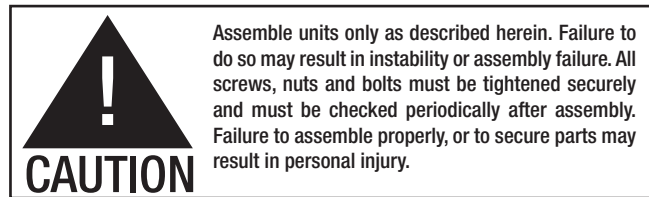

Rust removers contain harsh chemicals, which will quickly cause permanent damage. If a spill occurs, wipe off all residues immediately, wash thoroughly with soapy water and rinse several times. Steel wool and other abrasive pads will damage the laminate and powder coat face. Do not use them for cleaning and don't store steel wool pads on your countertop; the metal can rust and leave stains. Toilet bowl cleaners contain harsh chemicals that can cause permanent damage. If spills occur, wipe up immediately, wash surface with soapy water and rinse several times.

The cleaners listed below can cause damage to the surface of laminate:

Chemical Ingredient	Synonymous Names
Hydrochloric Acid	Muriatic Acid Hydrogen Chloride
Sulfuric Acid	Oleic Acid Oil of Vitriol Oleum
Hydrofluoric Acid	Rust Remover
Phosphoric Acid	Rust Remover
Sodium Hydroxide	Caustic Soda Caustic Soda Lye Lye
Pumice (abrasive)	

Remember, sharp objects can damage the surface of laminate and powder coat surfaces, marring its beauty and lowering wear and stain resistance. Although the laminate and powder coat surfaces are somewhat resistant to scratch and marring, they can be damaged, even under normal use.

Laminate and powder coat surfaces may need occasional dusting depending on where it's used. To keep the surface beautiful, use a non-oily furniture spray. (Remember to clean the spray off several times a year to prevent build-up.) Furniture polish can also help hide fine scratches in the surface.

UPHOLSTERED FABRIC: Clean with water-based cleaning agents, foam or pure water-free solvents. Vacuuming or light brushing is recommended to prevent dust and soil buildup. For answers to additional questions regarding care or cleaning please contact Sedia Systems.

G20 Auditorium Seating Assembly Instructions



Assemble units only as described herein. Failure to do so may result in instability or assembly failure. All screws, nuts and bolts must be tightened securely and must be checked periodically after assembly. Failure to assemble properly, or to secure parts may result in personal injury.

CAUTION

System Components

Gravity Lift Seat

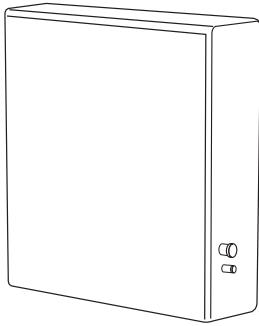

20 - 26 Inch Widths

Standard Back

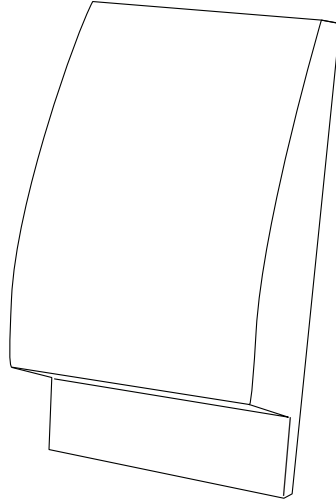

High Back

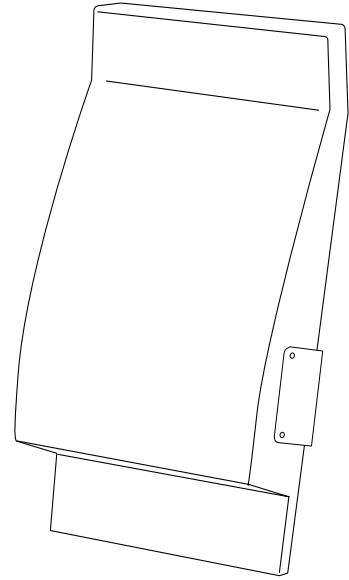

Arm Standards

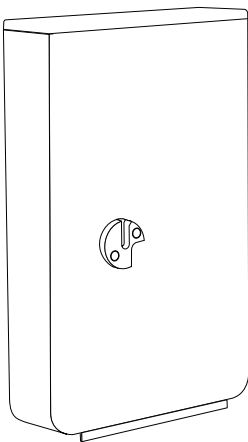

- Arm Standard**
- Left Side
 - Right Side
 - Center

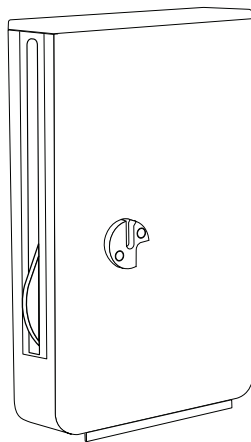

- Tablet Arm Standard**
- Left Side
 - Right Side
 - Center

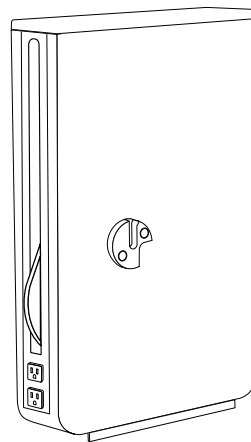

- Power Option**
- Left Side
 - Right Side
 - Center

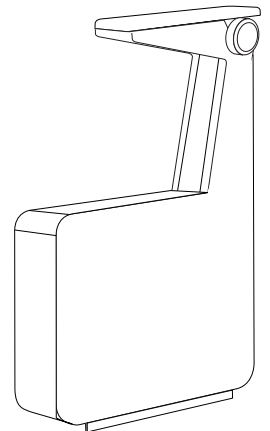

- ADA Standard**
- Left Side
 - Right Side

G20 Auditorium Seating Assembly Instructions

Floor Mounted Chair

**CAUTION**

Assemble units only as described herein. Failure to do so may result in instability or assembly failure. All screws, nuts and bolts must be tightened securely and must be checked periodically after assembly. Failure to assemble properly, or to secure parts may result in personal injury.

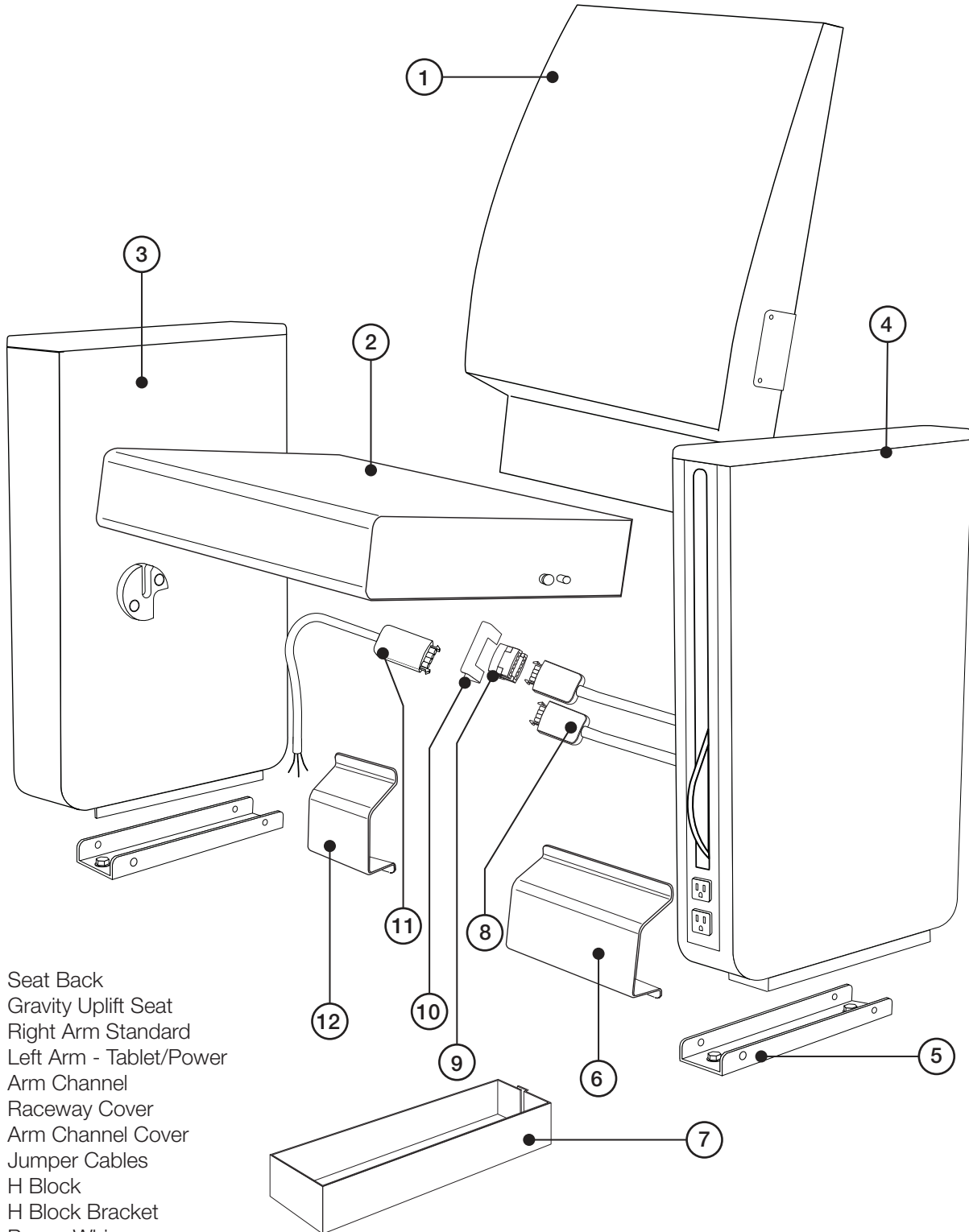

1. Seat Back
2. Gravity Uplift Seat
3. Right Arm Standard
4. Left Arm - Tablet/Power
5. Arm Channel
6. Raceway Cover
7. Arm Channel Cover
8. Jumper Cables
9. H Block
10. H Block Bracket
11. Power Whip
12. End Cover

G20 Auditorium Seating Assembly Instructions

Site Preparation



Assemble units only as described herein. Failure to do so may result in instability or assembly failure. All screws, nuts and bolts must be tightened securely and must be checked periodically after assembly. Failure to assemble properly, or to secure parts may result in personal injury.

CAUTION

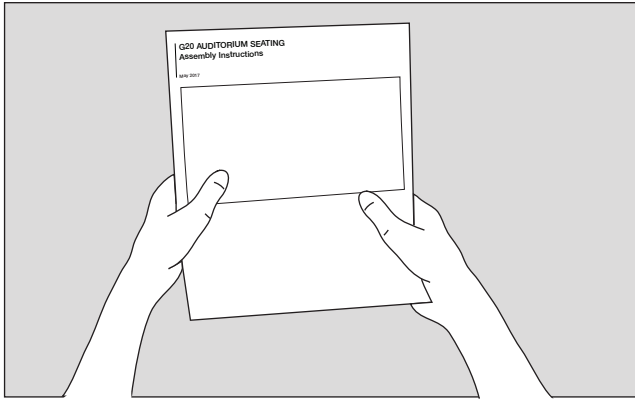

Step 1: Read and review the assembly instructions.

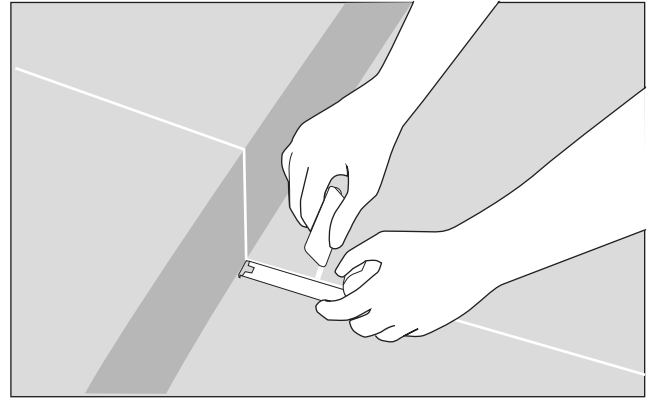

Step 4: Use layout drawing to locate row size line from back of riser and mark with chalk.

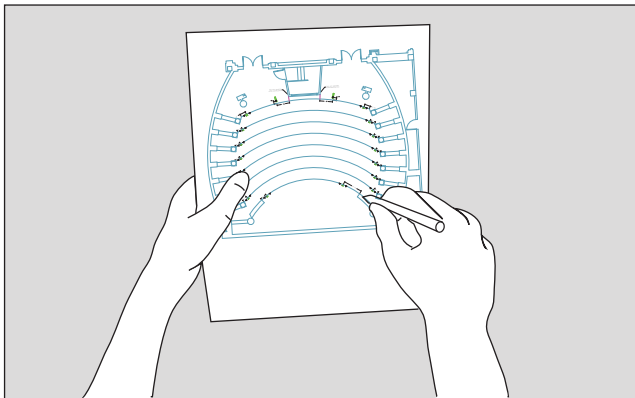

Step 2: Refer to layout drawings and verify room dimensions.

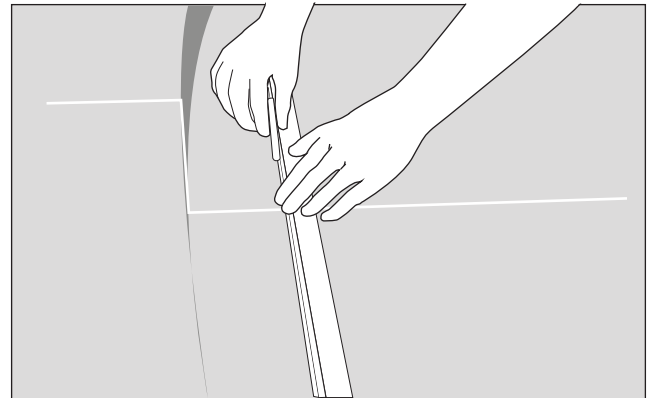

Step 5: Draw the size line. For radius floor, use 1/4 round or equivalent to get the radius size line.

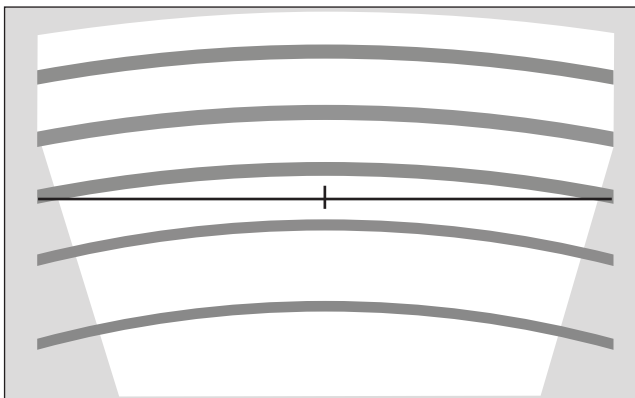

Step 3: Use tape measure to locate room center and other reference dimensions and mark with chalk

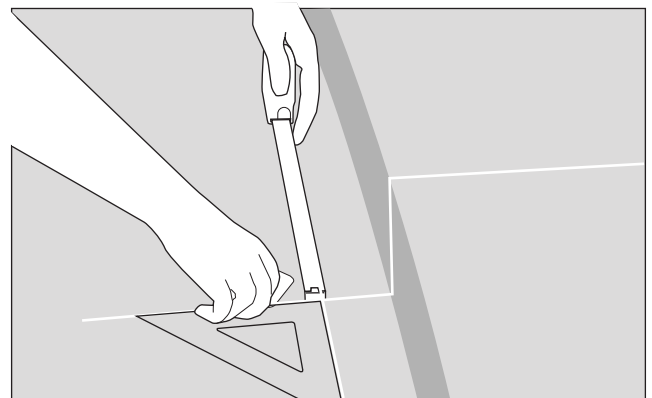

Step 6: Mark hole locations of the first chair symmetric about the center line and according to the drawing.

G20 Auditorium Seating Assembly Instructions

Site Preparation



Assemble units only as described herein. Failure to do so may result in instability or assembly failure. All screws, nuts and bolts must be tightened securely and must be checked periodically after assembly. Failure to assemble properly, or to secure parts may result in personal injury.

CAUTION

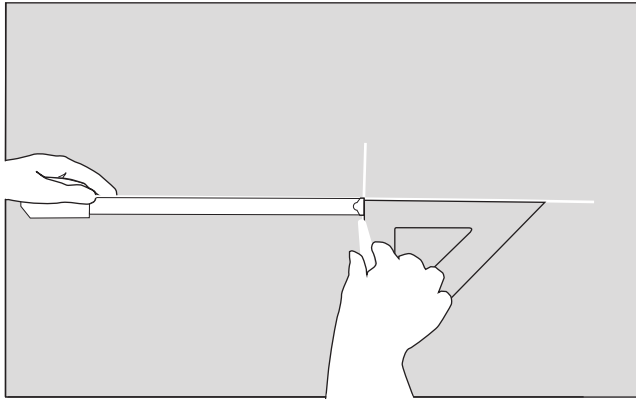

Step 7: Mark all hole locations by incrementing dimensions sequentially as per drawing.

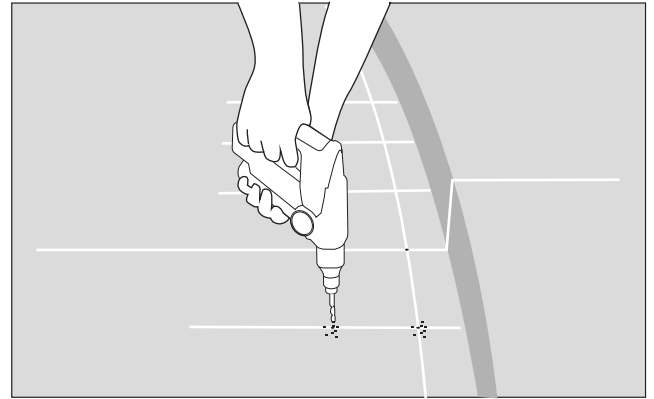

Step 10: Drill holes using 1/4" x 4" concrete drill bit. Concrete Floor - 2 holes, Wood Floor - 2 pilot holes only.

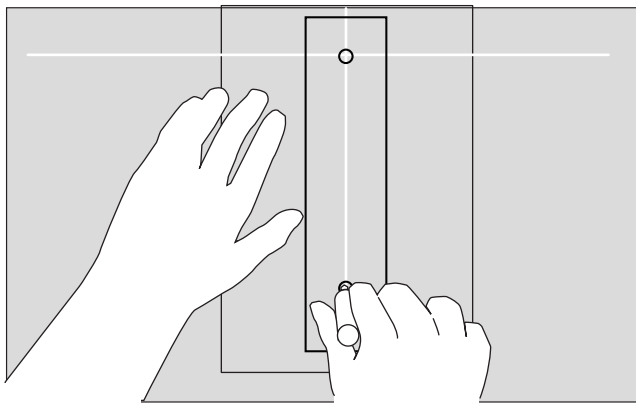

Step 8: Center drill template and mark hole locations.

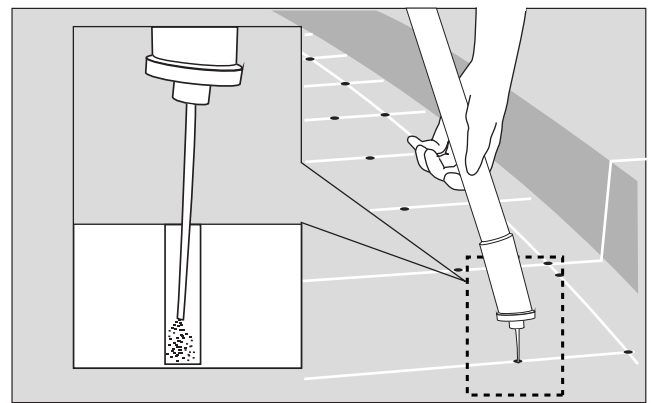

Step 11: Vacuum holes to remove wood/concrete particles.

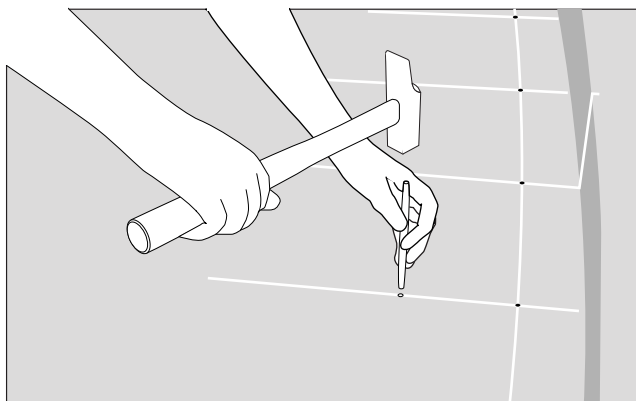

Step 9: Punch carpet using hammer and punch. Remove thread material and ensure drill area is free of debris.

G20 Auditorium Seating Assembly Instructions

Chair Installation



Assemble units only as described herein. Failure to do so may result in instability or assembly failure. All screws, nuts and bolts must be tightened securely and must be checked periodically after assembly. Failure to assemble properly, or to secure parts may result in personal injury.

CAUTION

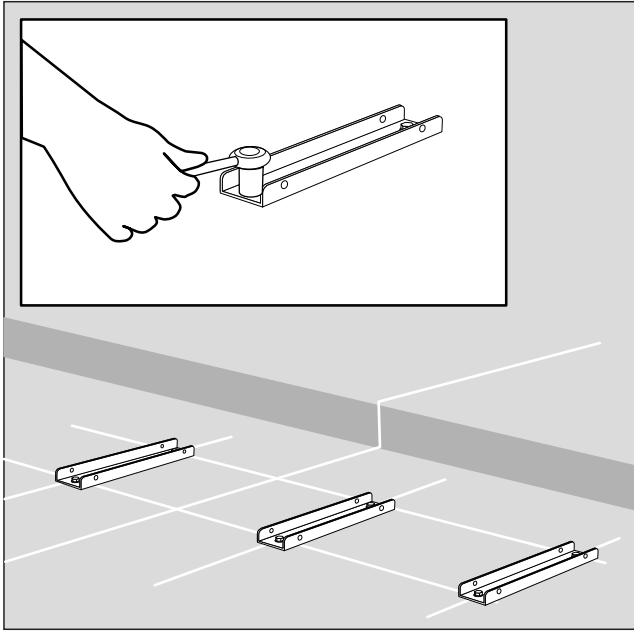

Step 12: Align arm channel with anchor holes and fasten with wood or concrete anchors.

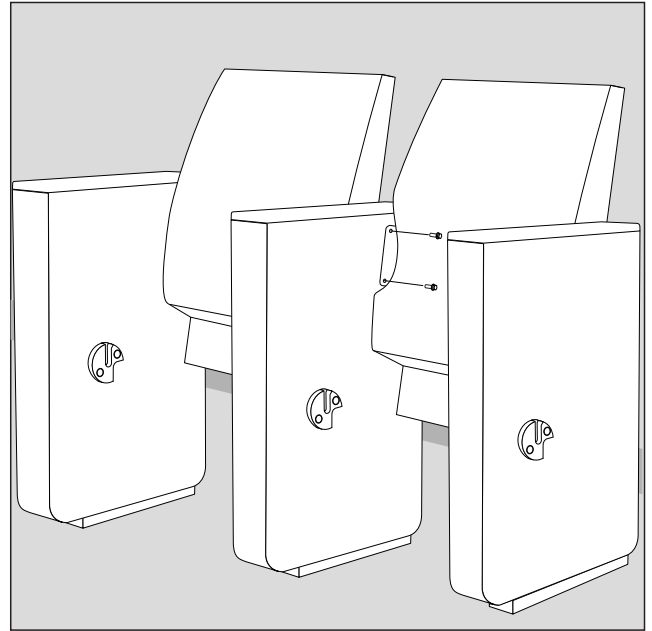

Step 14: Assemble chair back by aligning metal bracket on seat back with holes in arm standard. Attach with (4) provided M8 x 20mm button head socket cap screws.

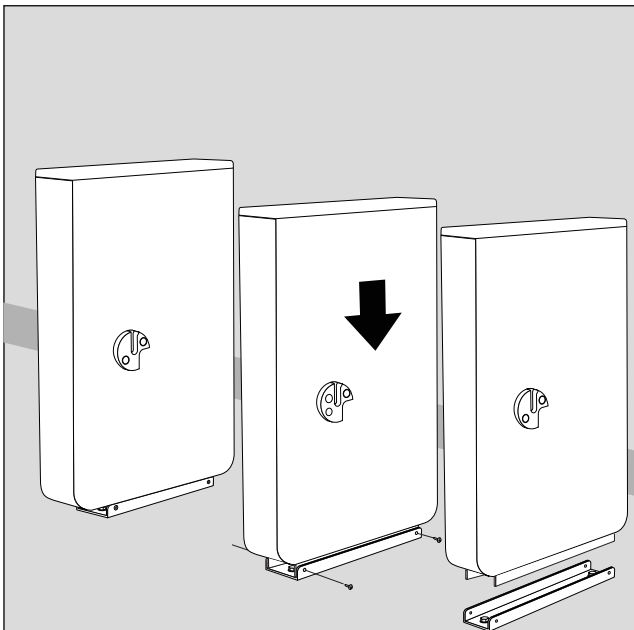

Step 13: Assemble arms to arm channels with (4) provided M8 x 12mm flat head socket cap screws.

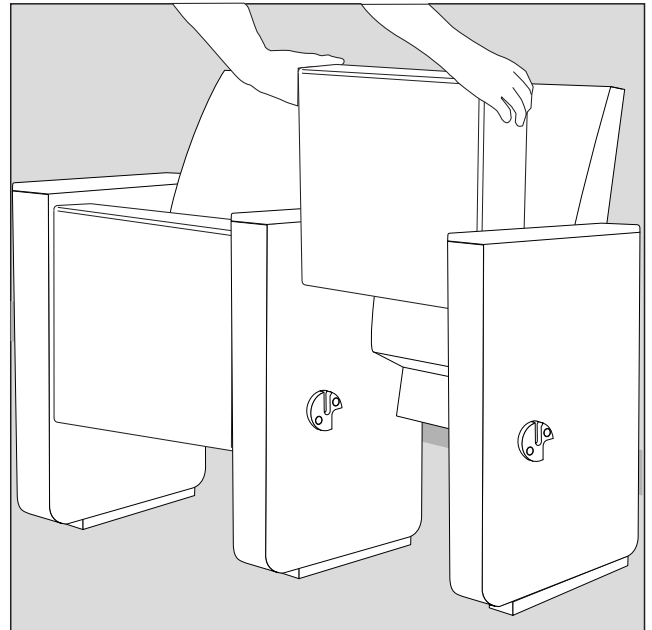

Step 15: Assemble seat to pivot disc by inserting the pins so they engage into the pivot disc slot.

G20 Auditorium Seating Assembly Instructions



Assemble units only as described herein. Failure to do so may result in instability or assembly failure. All screws, nuts and bolts must be tightened securely and must be checked periodically after assembly. Failure to assemble properly, or to secure parts may result in personal injury.

CAUTION

System Components

Power System

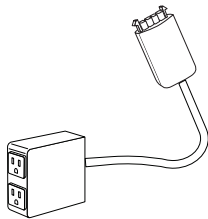

Duplex Power Module

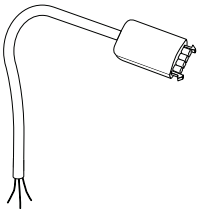

Power Whip
72 - 300 Inches



H Block
Bracket



H Block

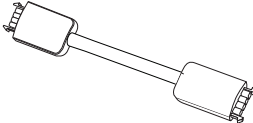

Jumper Cable
Lengths Based
on Layout Drawing
8 - 300 Inches

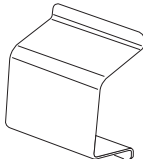

End Cap

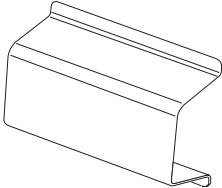

Raceway Cover

G20 Auditorium Seating Assembly Instructions

Chair Installation

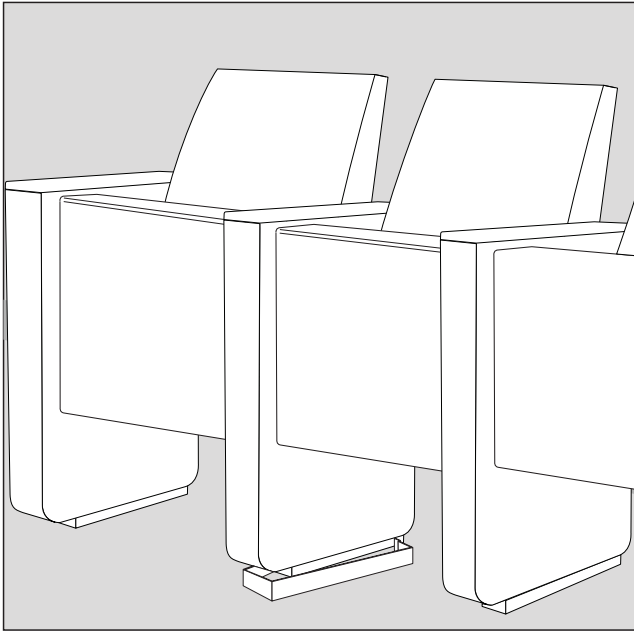
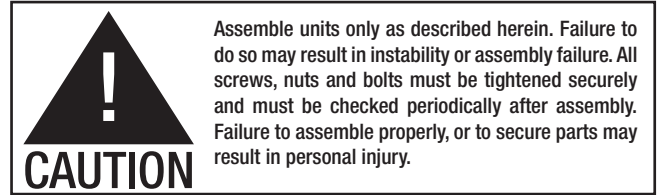

Step 16: Gently flex the arm channel cover to fit around the arm channel. Fasten on rear with (1) provided M3.9 x 9.5mm phillips pan head tapping screw.

G20 Auditorium Seating Assembly Instructions

Power System Installation

**CAUTION**

Assemble units only as described herein. Failure to do so may result in instability or assembly failure. All screws, nuts and bolts must be tightened securely and must be checked periodically after assembly. Failure to assemble properly, or to secure parts may result in personal injury.

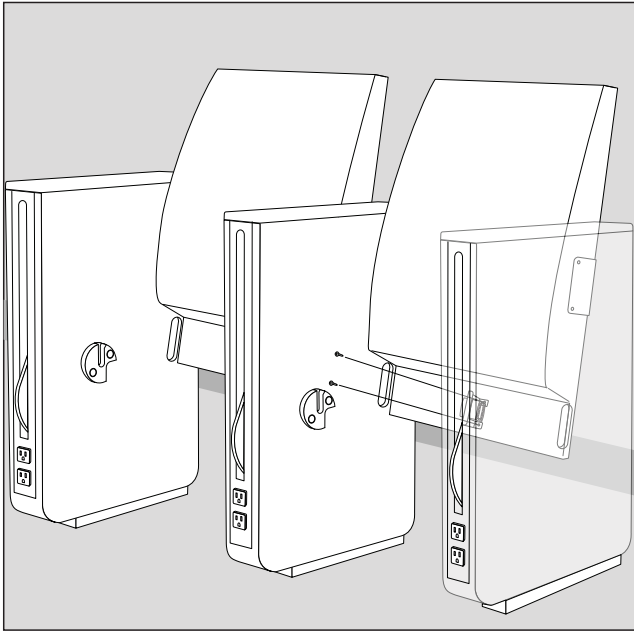

Step 1: Before the seats are installed, mount the H Block with the H Block brackets to the center of the seat back with wood screws provided.

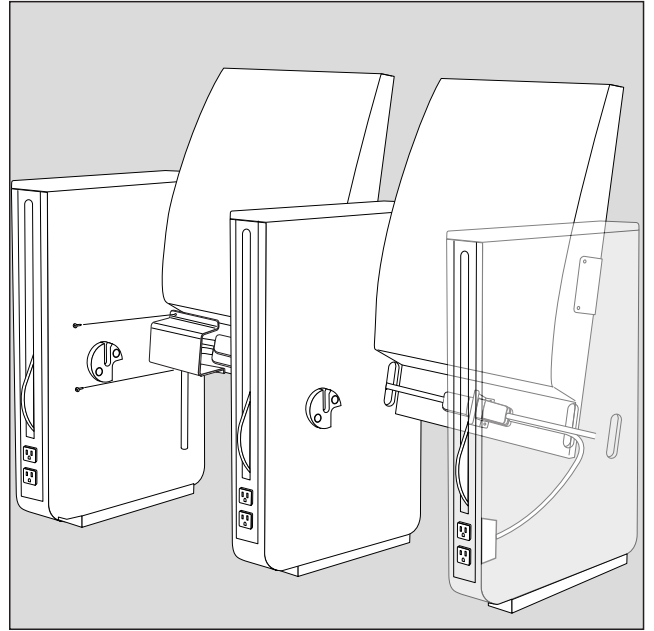

Step 3: Install end covers with (2) provided wood screws as shown on layout drawings.

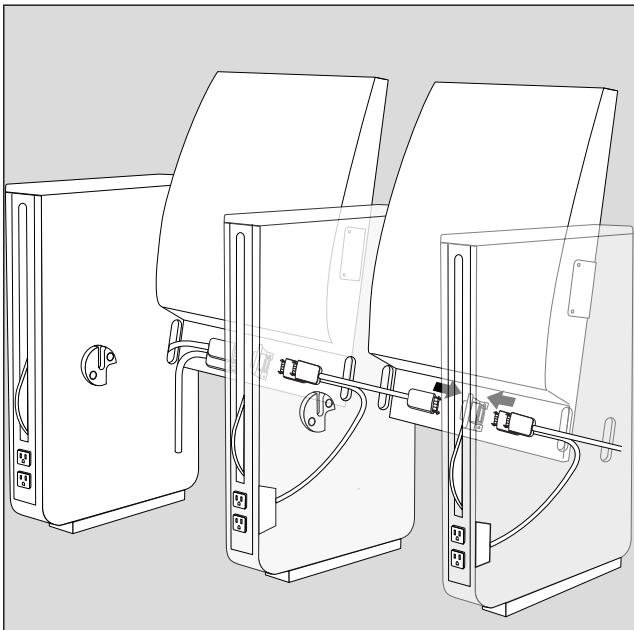

Step 2: Plug power modules and jumper cables into H-Blocks as shown on layout drawings.

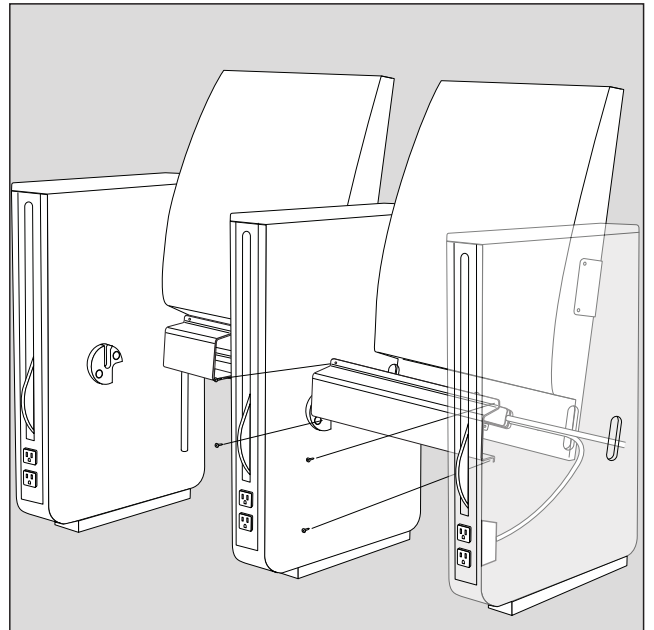

Step 4: Install raceway covers with (4) provided wood screws. Raceway covers will overlap the end covers.

G20 Auditorium Seating Assembly Instructions

Power System Installation

**CAUTION**

Assemble units only as described herein. Failure to do so may result in instability or assembly failure. All screws, nuts and bolts must be tightened securely and must be checked periodically after assembly. Failure to assemble properly, or to secure parts may result in personal injury.

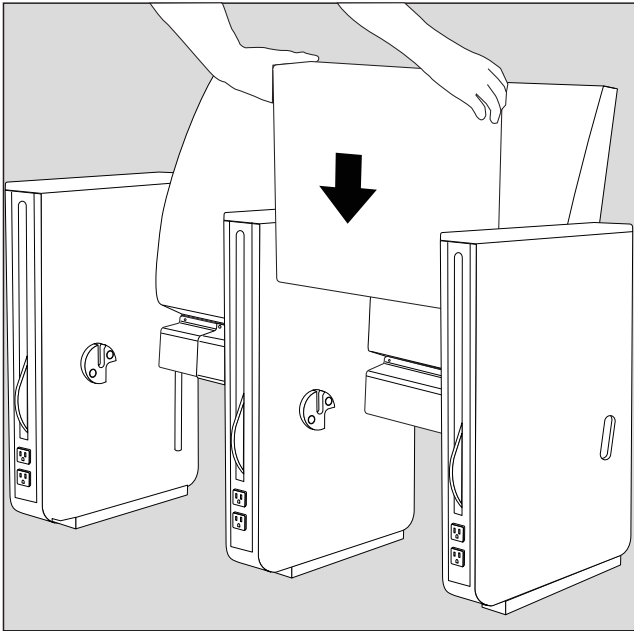

Step 5: Assemble seat to pivot disc by inserting the pins so they engage into the pivot disc slot.

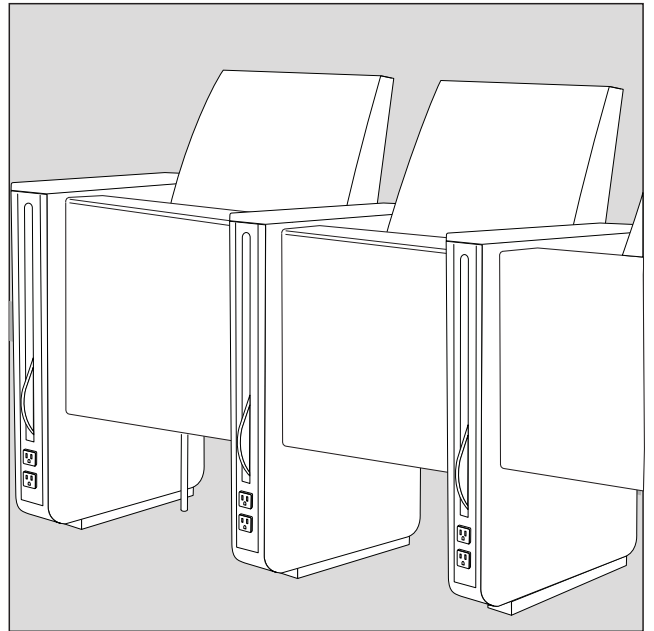

Step 7: Connect power system whip to building power supply per the 4-wire/2-circuit schematic.

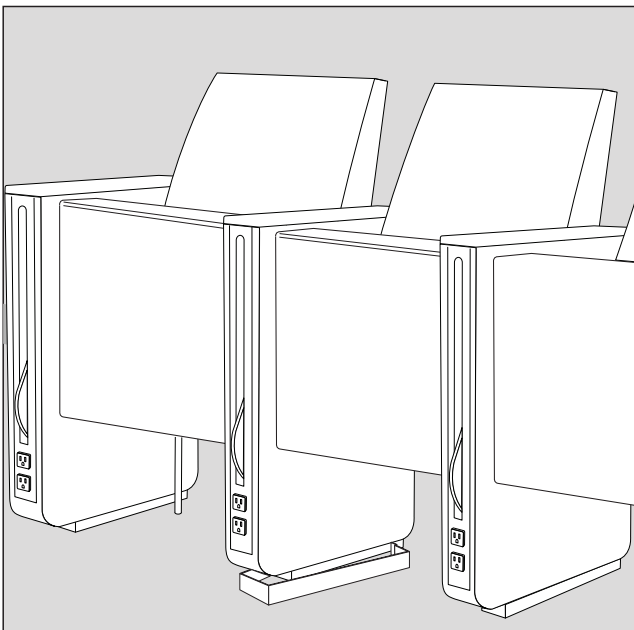

Step 6: Gently flex the arm channel cover to fit around the arm channel. Fasten on rear with (1) provided M3.9 x 9.5mm phillips pan head tapping screw.